



VGD20...



VGD40.../VGD41...

Double gas valves

VGD2...
VGD4...

- Double gas valves of class A for integration into gas trains
- Safety shutoff valves conforming to EN 161 in connection with SKPx5... actuators
- Suited for use with gases of gas families I...III
- Double gas valves in connection with SKPx5... actuators open slowly and close rapidly
- 2-port valves of the normally closed type
- Sizes 1" ... DN 150
- The double gas valves are designed for combination with 2 actuators
- Supplementary Data Sheets on actuators: See *Mechanical design*
- Models for the USA on request

The VGD2.../VGD4... and this Data Sheet are intended for use by OEMs which integrate the double gas valves in their products!

Use

The double gas valves are primarily suited ...

- On gas-fired combustion plant
- In gas trains in connection with forced draft gas burners

They serve as:

- Shutoff valves (in connection with SKP15... actuators)
- Control valves with shutoff feature (in connection with SKP25..., SKP55... or SKP75... actuators)

All types of double gas valves can be combined with any type of SKPx5... actuator.

Warning notes



To avoid injury to persons, damage to property or the environment, the following warning notes must be observed!

Do not open, interfere with or modify the double gas valves!

Any opening of the valve, replacement of parts or modifications to the original product is the user's responsibility and is done at his own risk.

- All activities (mounting, installation and service work, etc.) must be carried out by qualified staff
- Fall or shock can adversely affect the safety functions. Such valves must not be put into operation, even if they do not exhibit any damage
- In combination with the valve proving system from other manufacturers, the suitability must be checked individually for the plant

Mounting notes

- Ensure that the relevant national safety regulations are complied with
- The actuator can be fitted or replaced while the valve is under gas pressure
- Also observe the following Mounting Instructions:

VGD...	M7631/M7636	4 319 2072 0
VGD2...	M7631	4 319 2343 0
VGD20...	M7631.5	A5W00002883
VGD4... for DN 40...150	M7631.2	74 319 0244 0
AGA66	M7643.2	74 319 0421 0
AGF10...	M7631/M7646	74 319 0865 0

- With SKP25...: Impulse pipe (pressure feedback) on double valve possible
- With SKP75...: Impulse pipe (pressure feedback) must be connected to the gas pipe, downstream from the valve, observing a distance of at least 3...5 D

Gasket/tightness

- Check to ensure that the bolts on the flanges are properly tightened; then make certain that the connections with all components are tight
- The O-rings or flange gaskets must be fitted between the flanges and the double valve

Mounting position

The permissible mounting positions of the actuators must be observed (refer to the relevant Data Sheet N7643).

Direction of flow

The direction of gas flow must be in accordance with the direction of the arrow on the valve body.

Function

The double gas valve is normally closed and opened when the SKPx5... actuator opens.

VGD20... (not for VGD20.xxxxY)

- Mount the electrohydraulic SKP15... actuator on the valve's inlet side and the actuator with integrated gas pressure governor (SKP25..., SKP55... or SKP75...) on the valve's outlet side
- When mounting the double gas valve in the gas train, 2 AGF10... flanges are required
- When replacing a VGD20 on existing AGF10 flanges, new O-rings must be mounted
- When replacing a VGD20 on existing AGA41 / AGA51 flanges (old flange series), new O-rings and longer screws (M8 x 35) must be mounted (service replacement kit AGA92)
- To prevent cuttings from falling inside the valve, first fit the flanges to the piping and then clean the respective parts. Then, clean the parts before installing the VGD20.

Standards and certificates



Note!
Only in conjunction with SKPx5 / SKLx5, see Data Sheet N7643.



EAC Conformity mark (Eurasian Conformity mark)



ISO 9001:2008
ISO 14001:2004
OHSAS 18001:2007



China RoHS
Hazardous substances table:
<http://www.siemens.com/download?A6V10883536>

AGF10 only



Applied directives:

- Directive for gas-fired appliances 2009/142/EC



Compliance with the regulations of the applied directives is verified by the adherence to the following standards / regulations:

- Safety and control devices for gas burners and gas burning appliances DIN EN 13611

The relevant valid edition of the standards can be found in the declaration of conformity!

Standards and certificates (cont'd)

Approvals in connection
with SKPx5... actuator

Type		
VGD20.403	●	●
VGD20.503	●	●
VGD20.2511	●	●
VGD20.3211	●	●
VGD20.4011	●	●
VGD20.4011A **)	●	●
VGD20.4011Y	●	●
VGD20.5011	●	●
VGD20.5011A **)	●	●
VGD20.5011Y	●	●
VGD40.040	●	●
VGD40.050	●	●
VGD40.065	●	●
VGD40.080	●	●
VGD40.100	●	●
VGD40.125	●	●
VGD40.150	●	●
VGD40.040L	●	---
VGD40.050L	●	---
VGD40.065L	●	---
VGD40.065J	●	---
VGD40.080L	●	---
VGD40.080J	●	---
VGD40.100L	●	---
VGD40.125L	●	---
VGD40.150L	●	---
VGD41.040	●	---
VGD41.050	●	---
VGD41.065	●	---
VGD41.080	●	---
VGD41.100	●	---
VGD41.125	●	---
VGD41.150	●	---

**) Not yet available

Life cycle

The combination gas valve VG... and actuator have a designed lifetime* of

Nominal sizes	Burner startup cycles
≤25 DN	200.000
25...80 DN	100.000
80...150 DN	50.000

under use of gases to EN 437 (or DVGW specification G260).

This lifetime is based on the endurance tests in the standard EN 161.
A summary of the conditions has been published by the European Control Manufacturers Association (Afecor) (www.afecor.org).

The designed lifetime is based on use of the gas valve VG... and actuator according to the manufacturer's Data Sheet. After reaching the designed lifetime in terms of the number of burner startup cycles, or the respective time of usage, the gas valve VG... and actuator are to be replaced by authorized personnel.

* The designed lifetime is not the warranty time specified in the Terms of Delivery

Service notes

- Each time a double gas valve has been replaced, check the correct functioning and the internal and external tightness of the valve
- The double gas valves supplied by Siemens may **only** be repaired by Siemens Repair Centers

Disposal notes



Local and currently valid legislation must be observed.

Mechanical design

Strainer

A strainer made of stainless steel is fitted near the valve's inlet to protect the valve, the seat and the disk as well as downstream devices against dirt.

AGF10... connecting flanges for VGD2...

The connecting flanges have a 1/8" test point. They are internally threaded and supplied as separate items together with the necessary accessories, such as bolts, nuts, and gaskets. A Each thread dimension of the AGF10 can be mounted on a VGD2 as desired. Each double gas valve requires 2 connecting flanges.

VGD2...

Sectional view of VGD2...

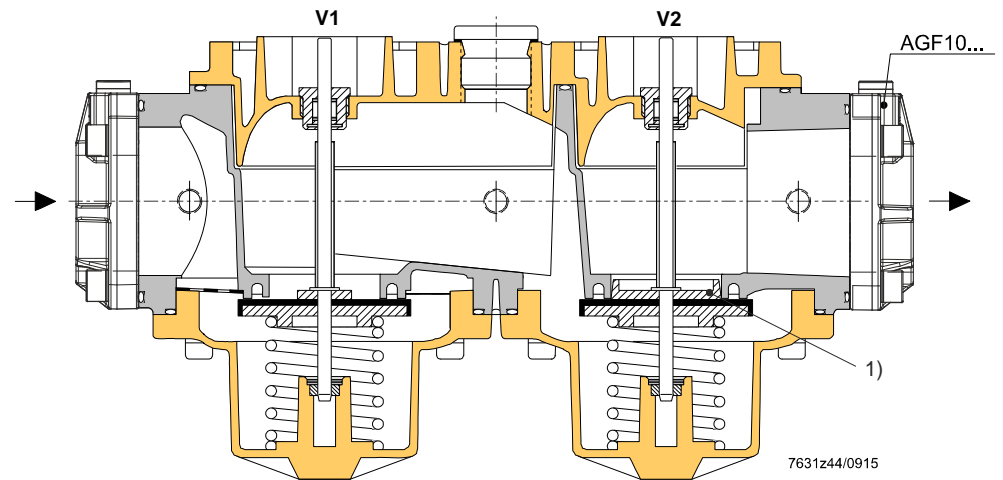

1) Profile not required with VGD20.xxxxY

Application example

VGD2... with SKP15... (mounted on V1) and SKP75... (mounted on V2)

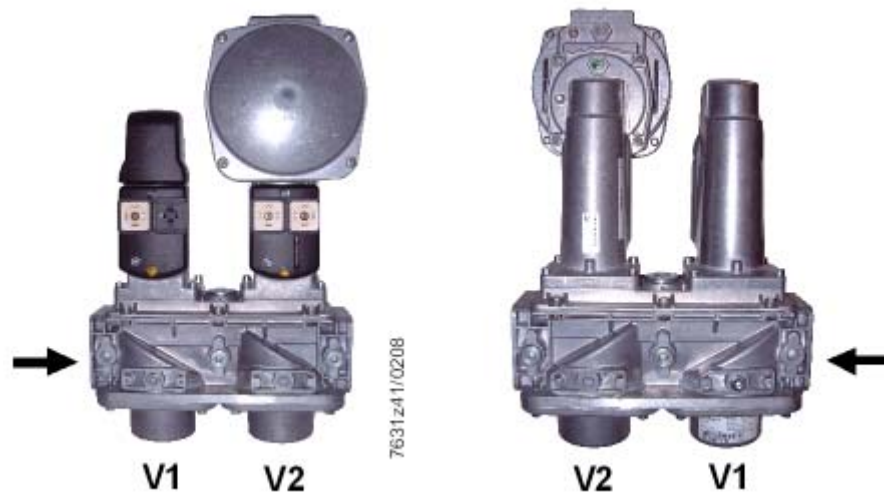

Mechanical design (cont'd)

VGD4...

The VGD4... double gas valves are double-seat disk valves. The 1/4" impulse connection at the pilot gas flange, or the impulse connection at the outlet of valve **V1** or **V2**, can be connected to the impulse connection of the mounted constant pressure governor SKP25...

Closing springs

Each double seat uses one pair of springs. The spring forces act separately as closing forces on the individual valve seats.

Pressure switch plate

Pressure switch plate ① facilitates attachment of a number of commercially available pressure switches or valve proving devices. Pilot gas flange ② and pressure switch plate can be fitted on either side of the valve.

VGD40...

Sectional view of VGD40...

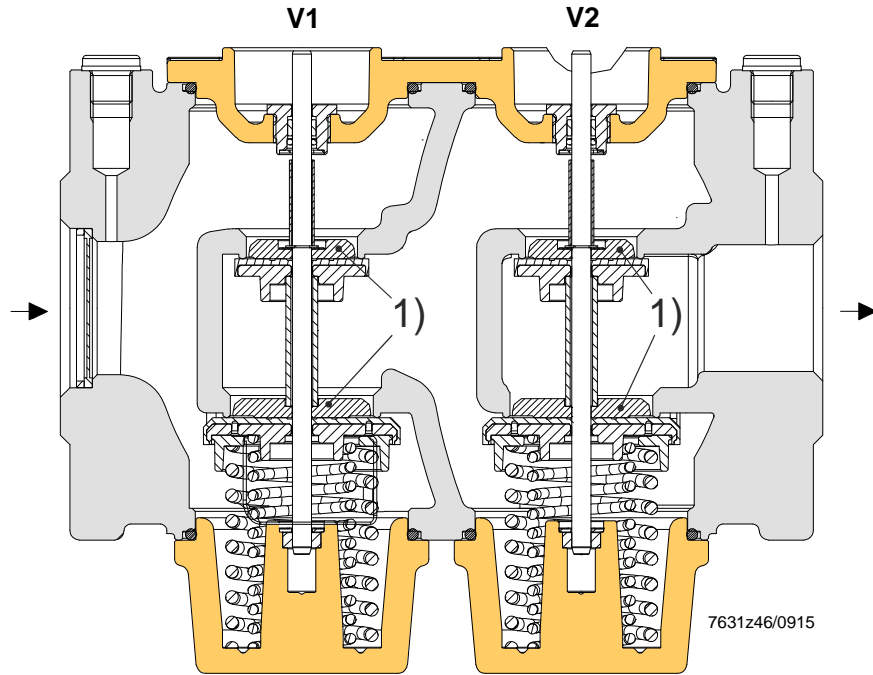

1) Profile not required with VGD41.xxxxY

Application example

VGD40.080 with SKP15... (mounted on valve **V1**) and SKP25... (mounted on valve **V2**).

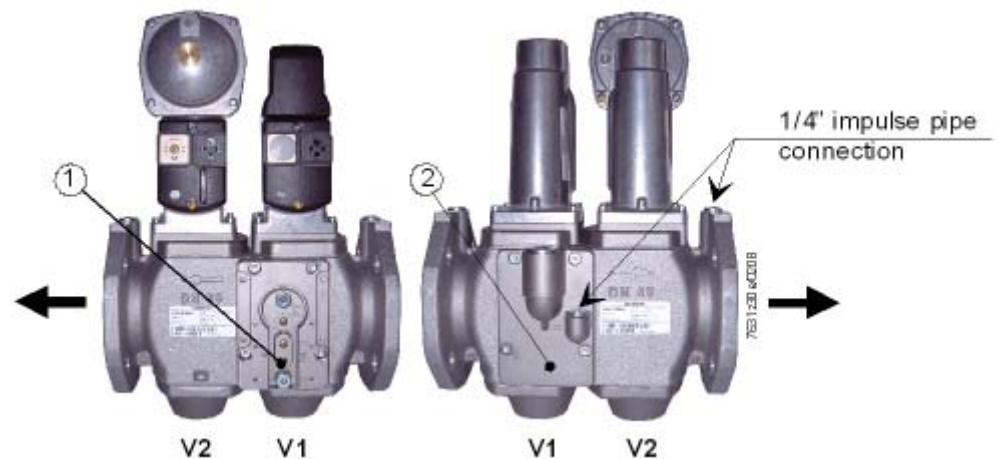

Actuators

The double gas valves can be combined with the following types of actuators:

Product no.	Data Sheet	Function
SKP15...	N7643	ON/OFF
SKP25...	N7643	ON/OFF with constant pressure control/zero pressure control
SKP25.7... with SQS37...	N7643	ON/OFF with pressure control, predefined setpoint adjustable via electrical signal
SKP55...	N7643	ON/OFF with differential pressure control, signal input → differential pressure
SKP75...	N7643	ON/OFF with fuel / air ratio control, signal input → static pressure

Type summary (other types of valves on request)

VGD2...

Nominal size	Flow rate at $\Delta p = 1 \text{ kPa m}^3/\text{h}$ air	With 3 internally threaded connections		With 11 internally threaded connections		With 11 internally threaded connections With no contoured disk on the valve seat (V2) for quicker gas release	
		Article no.	Type	Article no.	Type	Article no.	Type
1"	25	---	---	BPZ:VGD20.2511	VGD20.2511	---	---
1 ¼"	46	---	---	BPZ:VGD20.3211	VGD20.3211	---	---
1 ½"	85	BPZ:VGD20.403	VGD20.403	BPZ:VGD20.4011	VGD20.4011	BPZ:VGD20.4011Y	VGD20.4011Y
1 ½"	85	---	---	BPZ:VGD20.4011A *)	VGD20.4011A *)	---	---
2"	100	BPZ:VGD20.503	VGD20.503	BPZ:VGD20.5011	VGD20.5011	BPZ:VGD20.5011Y	VGD20.5011Y
2"	100	---	---	BPZ:VGD20.5011A *)	VGD20.5011A *)	---	---

*) Not yet available

VGD4...

DN	Flow rate at $\Delta p = 1 \text{ kPa m}^3/\text{h}$ air					VGD40. xxxL with inverted position of mounting plates (see <i>Dimensions</i>)		VGD41.xxx with pressure switch plate on both sides (see <i>Dimensions</i>) VGD41. xxx without internal valve seat profile for faster gas release	
		Article no.	Type	Article no.	Type	Article no.	Type	Article no.	Type
40	85	BPZ:VGD40.040	VGD40.040	---	---	BPZ:VGD40.040L *)	VGD40.040L *)	BPZ:VGD41.040	VGD41.040
50	100	BPZ:VGD40.050	VGD40.050	---	---	BPZ:VGD40.050L	VGD40.050L	BPZ:VGD41.050	VGD41.050
65	160	BPZ:VGD40.065	VGD40.065	BPZ:VGD40.065J	VGD40.065J	BPZ:VGD40.065L	VGD40.065L	BPZ:VGD41.065	VGD41.065
80	250	BPZ:VGD40.080	VGD40.080	BPZ:VGD40.080J	VGD40.080J	BPZ:VGD40.080L	VGD40.080L	BPZ:VGD41.080	VGD41.080
100	400	BPZ:VGD40.100	VGD40.100	---	---	BPZ:VGD40.100L	VGD40.100L	BPZ:VGD41.100	VGD41.100
125	630	BPZ:VGD40.125	VGD40.125	---	---	BPZ:VGD40.125L	VGD40.125L	BPZ:VGD41.125	VGD41.125
150	800	BPZ:VGD40.150	VGD40.150	---	---	BPZ:VGD40.150L	VGD40.150L	BPZ:VGD41.150 *)	VGD41.150 *)

*) On request

Ordering

When ordering, please give product no. of the double gas valve.

Actuators, double gas valve and flanges (only VGD2...) are supplied as single packs.

Example: VGD2...

Double gas valve 2" with 2 connecting flanges and 2 actuators

1 VGD20.503

2 actuators SKPx5...

2 AGF10.50

Example: VGD4...

Double gas valve DN80 with 2 actuators

1 VGD40.080

2 actuators SKPx5...

The lateral mounting plates (pilot gas connection and pressure switch plate) are included in the scope of delivery and ready fitted.

Accessories (to be ordered separately)



Connecting/mounting flange AGF10... to VGD2...

- Order flanges individually
- Flanges can be combined with the VGD2 as desired

The following flange sizes and flange threads are available:

Connecting flange		Nominal size (RP)	Length in mm
Article no.	Type		
BPZ:AGF10.15	AGF10.15	½"	26
BPZ:AGF10.20	AGF10.20	¾"	26
BPZ:AGF10.25	AGF10.25	1"	26
BPZ:AGF10.32	AGF10.32	1 ¼"	26
BPZ:AGF10.40	AGF10.40	1 ½"	26
BPZ:AGF10.50	AGF10.50	2"	30



Double nipple (e.g. connection of QPL25)

Double nipple (1/8" to 1/4") required on-site for mounting the gas pressure switch QPL25

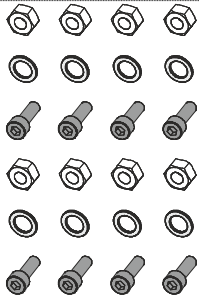

Service replacement kit for VGD20

AGA92

Article no. **S55851-Z901-A100**

- Required when replacing the VGD20 and retaining the old flanges AGA41 / AGA51
 - Screw dimensions M8 x 35
 - Consisting of:
8 screws, 8 circlips, 8 nuts, 2 O-rings
- See Mounting Instructions A5W00002883A



Manually operated

AGA61

Article no. **BPZ:AGA61**



Gasket set for SKPx5.../SKL25...

AGA66

Article no. **BPZ:AGA66**

- Between SKPx5.../SKL25... actuator and VG... valve
- For improving the degree of protection from IP54 to IP65
- Refer to Mounting Instructions M7643.2 (74 319 0421 0)

Technical data

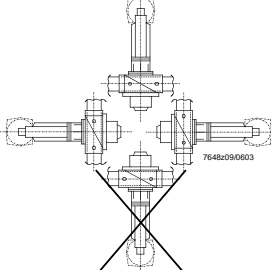
General valve data	Valve class (in connection with actuator)	A conforming to EN 161 (except with SAX31...)	
	Group	2 (EN 161)	
	Perm. medium temperature	-15...60 °C	
	Weight		
	- VGD2...	Approx. 3.2 kg	
	- VGD4...	See <i>Dimensions</i>	
	Connecting flanges for VGD4...	PN 16 to ISO 7005-2	
	Required flow rate	See <i>Flow chart</i>	
	Mounting position		
			
		See <i>Mounting notes</i>	
	Operating pressure	See <i>Type summary</i>	
	Types of gas		
	- VGD2... / VGD4...	Suited for use with gases of gas families I...III and air	
- VGD4...	Suitable for gases up to max. 0.1 Vol.-% H ₂ S, dry		
Strainer	Built in (mesh size 0.9 mm)		
Materials	AlSi10Mg to DIN 1706		
Environmental conditions	Storage	DIN EN 60721-3-1	
	Climatic conditions	Class 1K3	
	Mechanical conditions	Class 1M2	
	Temperature range	-20...60 °C	
	Humidity	<95% r.h.	
	Transport	DIN EN 60721-3-2	
	Climatic conditions	Class 2K2	
	Mechanical conditions	Class 2M2	
	Temperature range	-15...60 °C	
	Humidity	<95% r.h.	
	Operation	DIN EN 60721-3-3	
	Climatic conditions	Class 3K5	
	Mechanical conditions	Class 3M2	
	Temperature range	-10...60 °C	
Humidity	<95% r.h.		
Installation altitude	Max. 2,000 m above sea level		

Technical data (cont'd)

Permissible gas pressures/volumes	Product no.	Static pressure (perm. inlet pressure with double gas valve fully closed) (kPa)	Dynamic pressure (perm. operating pressure) (kPa)	Volume between V1/V2 (liters)
	VGD20.2...	150	150	0,75
	VGD20.3...	150	150	0,75
	VGD20.4...	150	150	0,75
	VGD20.5...	150	150	0,8
	VGD40.040	150	100	0,8
	VGD40.050	150	100	0,8
	VGD40.065	150	70	1,3
	VGD40.065J	150	70	1,3
	VGD40.080	150	70	1,5
	VGD40.080J	150	70	1,5
	VGD40.100	150	70	3
	VGD40.125	150	70	5,2
	VGD40.150	150	70	8,7

VGD40...

The double gas valves are designed to withstand gas pressures up to 150 kPa in burner standby mode. At a pressure of 150 kPa, the double valve remains safely shut or will safely close when shutdown is initiated by an upstream pressure signal. Proper functioning and outer tightness are not affected.

Note:

Owing to the internal design of the double valves, increasing inlet pressure causes the valve to close (class A conforming to EN 161). This means that safety shutoff or venting devices that – in addition to the high-pressure regulator – are normally used for protecting the gas valve on the burner are no longer required if the following conditions are satisfied:

- If, in the event the high-pressure regulator upstream of the valve fails, 150 kPa at the inlet of the double valve are not exceeded and,
- in the event the permissible pressure of the double valve is exceeded (DN 65...150: 70 kPa or DN 40...50: 100 kPa), a shutoff device (e.g. gas pressure switch) causes the double valve to close.

Example: Possibilities of fitting the pressure switch QPL15... with O-ring to the VGD20.xx11

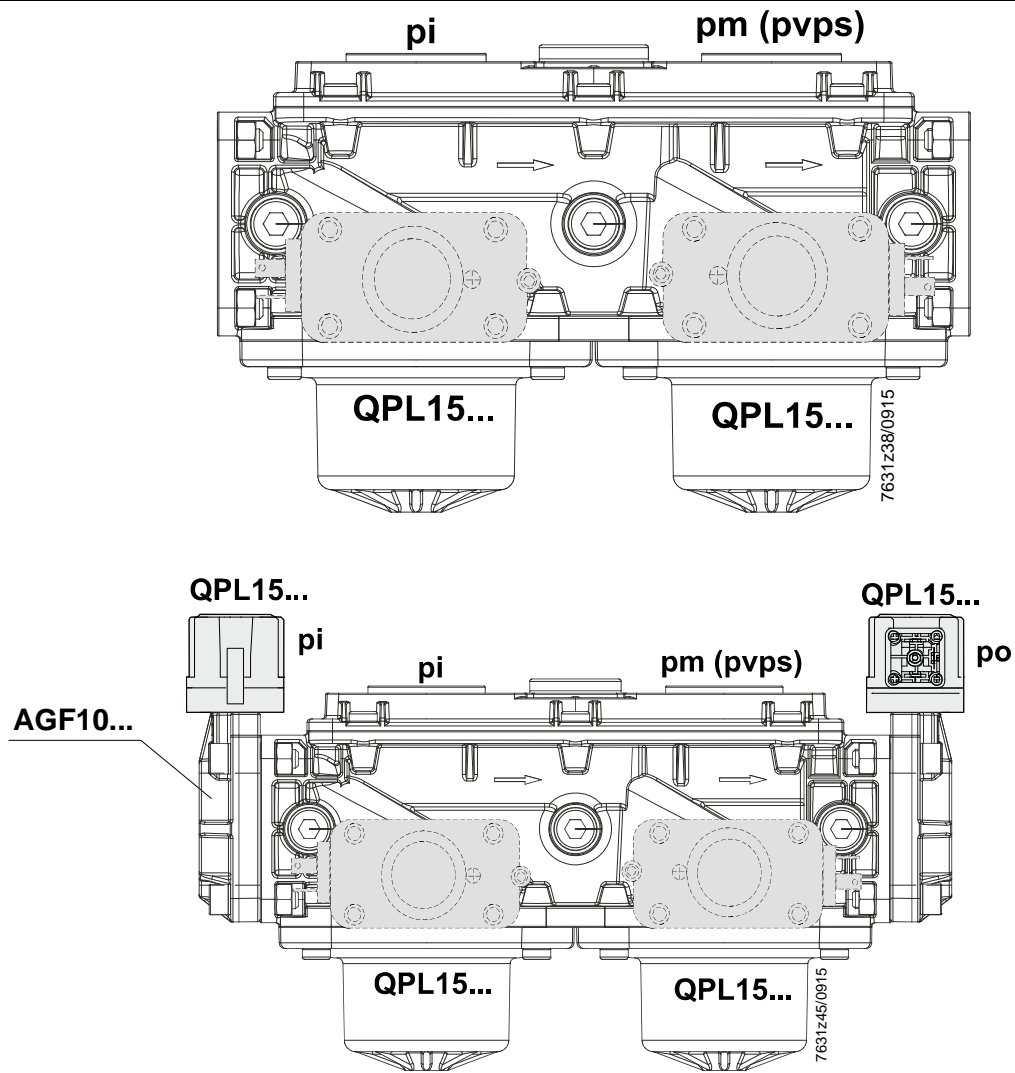

Example: Possibilities of fitting the pressure switch QPL25... with nipple to the VGD20.xx3... Rp $\frac{1}{4}$ "...1/8"

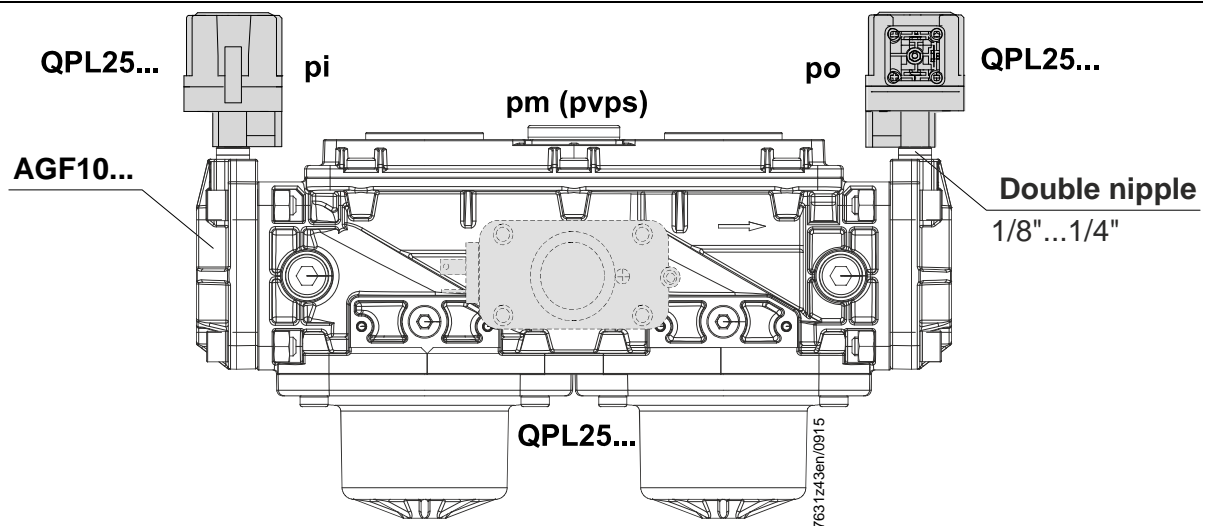

Example: Possibilities of fitting the pressure switch to the VGD4...

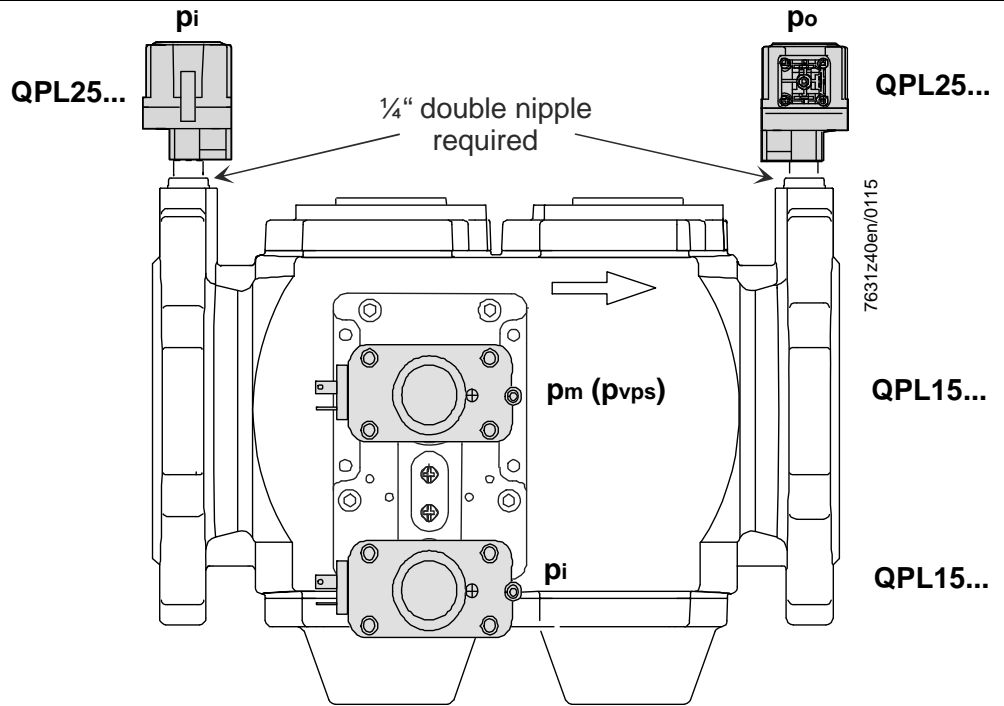

Legend

- pi = inlet pressure
- po = outlet pressure
- pm = mid-chamber pressure
- pvps = valve proving check

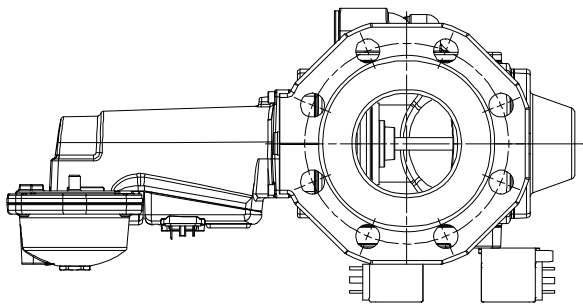
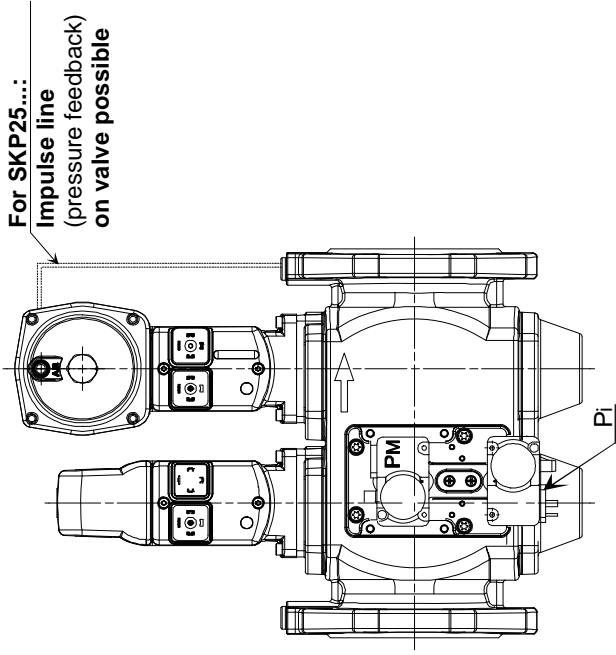

7631z34e/0915

Ancillary unit options (The use of various valve proving systems must be checked for the relevant plant):

Example (not binding):
 Valve proving device "B" and pressure switch (Pi)
 Valve proving device "B"
 (only up to size 100)

Example (not binding):
 Valve proving device "A" and pressure switch (Pi)

2 pressure switches (PM, Pi)

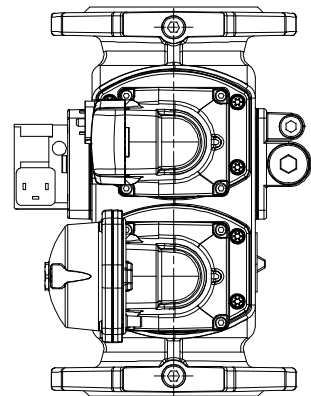
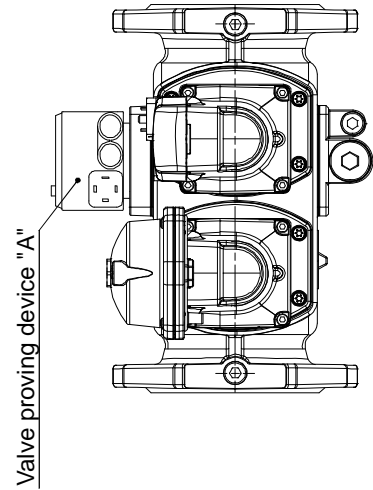
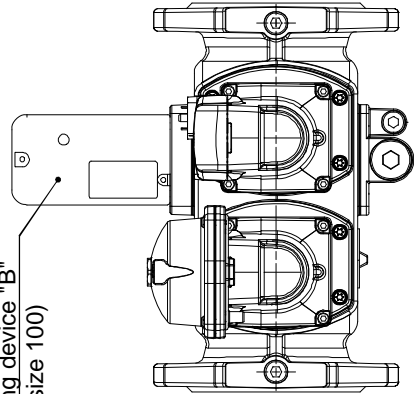

(Some of the ancillary units are products of other manufacture)

Flow chart of VGD... (only for fully open double valves)

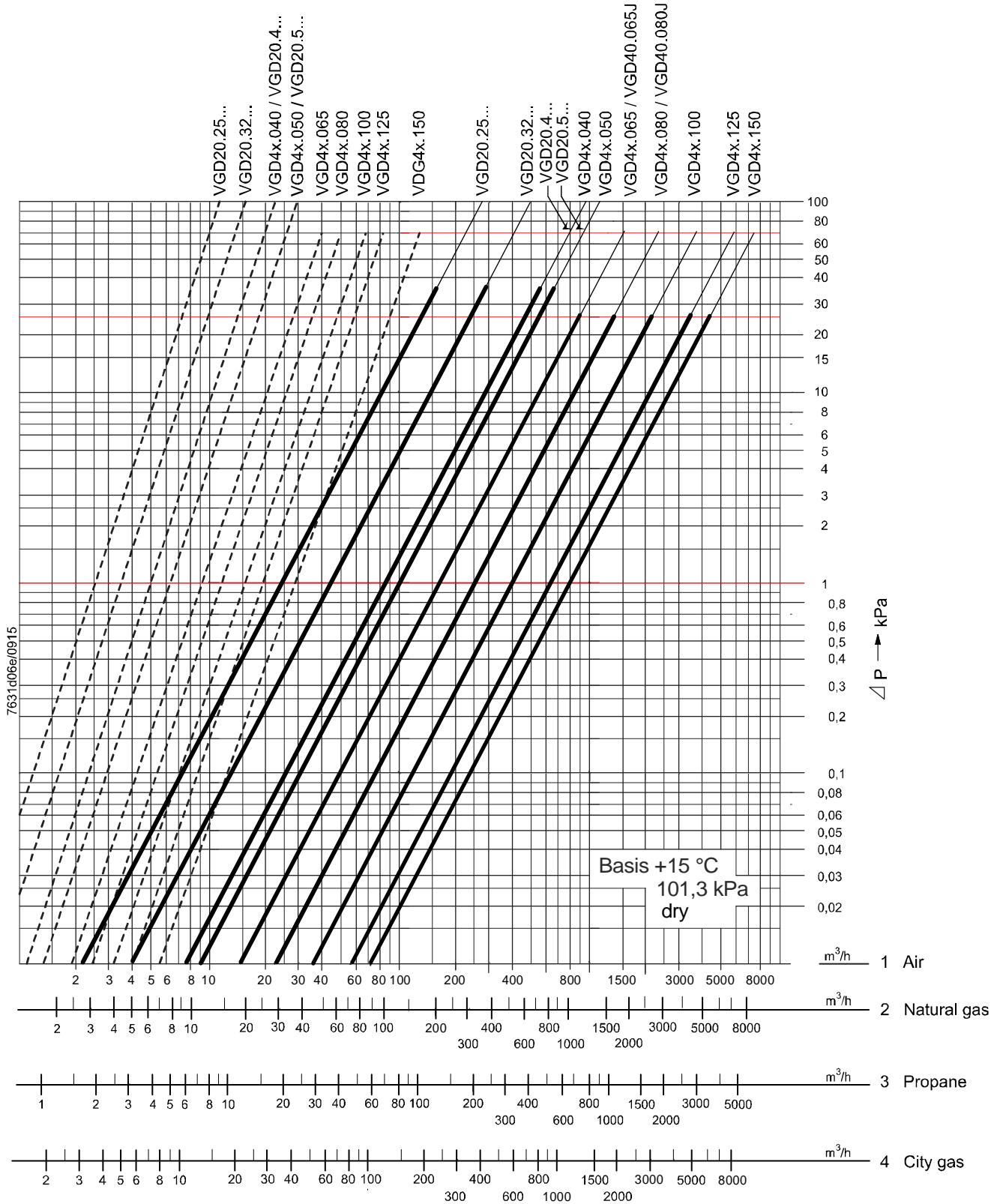

Legend:

- Minimum flow characteristic
- Maximum flow characteristic (double gas valve fully open)

Flow chart of VGD... (only for fully open double valves) (cont'd)

Operation beyond the range confined by the bold characteristics can lead to flow noise!



Attention!

- In the case of burners with small low-fire volumes, select a tightly sized valve (refer to the relevant Data Sheets on actuators)
- If the gas pressure exceeds the maximum permissible operating pressure, reduce it with a pressure regulator installed upstream of the valve
- The pressure drop (at maximum flow) is based on a fully open valve

Conversion of the air volume to a corresponding gas volume (natural gas)

Basis of scale

Abscissa	Medium Volumetric flow (QG) in m ³ /h	Density ratio (dv) to air	Conversion factor $f = \sqrt{\frac{1}{dv}}$
1	Air	1	1
2	Natural gas	0.61	1.28
3	Propane	1.562	0.8
4	Town gas	0.46	1.47

Conversion to air (m³/h) from other types of gases:

$$QL = \frac{QG}{f}$$

QL = amount of air m³/h producing the same pressure drop as **QG**

Example: Recommended working range (extract of VGD... flow chart)

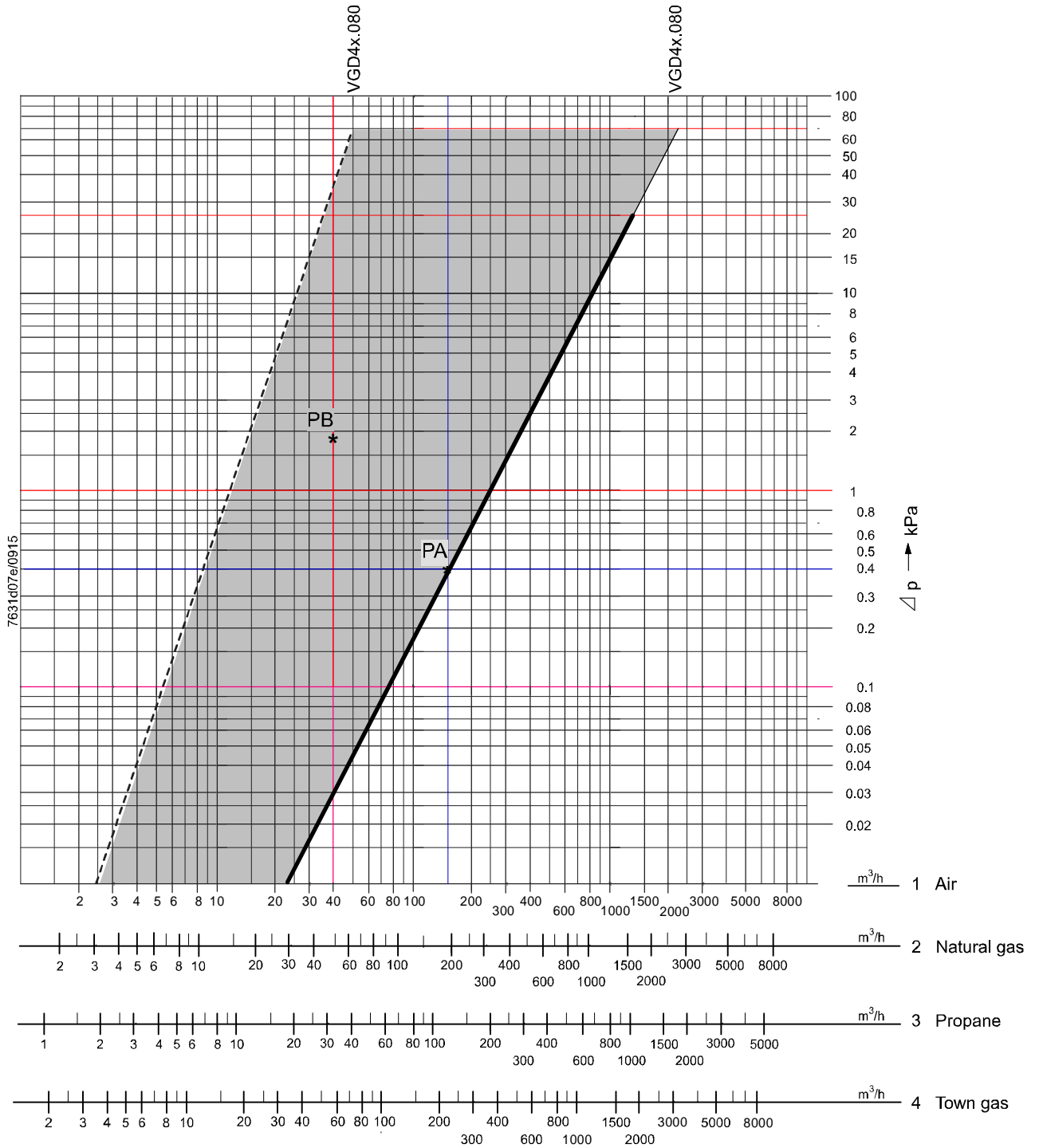

- Legend
- Minimum flow characteristic (can vary, depending of the quality of the pressure test points)
 - Maximum flow characteristic (double gas valve fully open)
 - PA Working point
 - PB Working point

Example: Recommended working range (extract of VGD... flow chart) (cont'd)

For points **PA/PB**, refer to «Sizing example» below.

Sizing example

Simplified calculation basis is carried out according to the above sizing chart: VGD with SKP75.

Prerequisite	Burner gas outlet toward the combustion chamber
Simplified example: Constant combustion chamber pressure	= 0 kPa
Required control ratio	RV = 4:1
Gas inlet pressure	2 kPa

1. **High-fire** → Point **PA** in the highlighted area
 Burner pressure at nominal load 1.6 kPa
 Volumetric flow at nominal load 200 m³/h natural gas, corresponding to 156 m³/h air
 - ΔpV... at nominal load 2.0 – 1.6 = 0.4 kPa
 Point **PA** must be on or to the left of the line representing the maximum flow characteristic

2. **Low-fire** → Point **PB** in the highlighted area

$$PG_{min} = \frac{PG_{max}}{RV^2} = \frac{1.6 \text{ kPa}}{16} = 0.1 \text{ kPa} \quad (\Delta p \text{ chart} = 2.0 - 0.1 = 1.9 \text{ kPa})$$

$$VG_{min} = \frac{VG_{max}}{RV} = \frac{200 \text{ m}^3/\text{h}}{4} = 50 \text{ m}^3 \text{ corresponding to } h = 39 \text{ m}^3/\text{h air}$$

– Selected valve size VGD40.080

Point **PB** must be on or to the right of the line representing the minimum flow characteristic.

Dimensions (not to scale)

Dimensions in mm



Note!
The VGD20 may only be mounted in conjunction with AGF10 flanges.

VGD20.xx3... with AGF10...

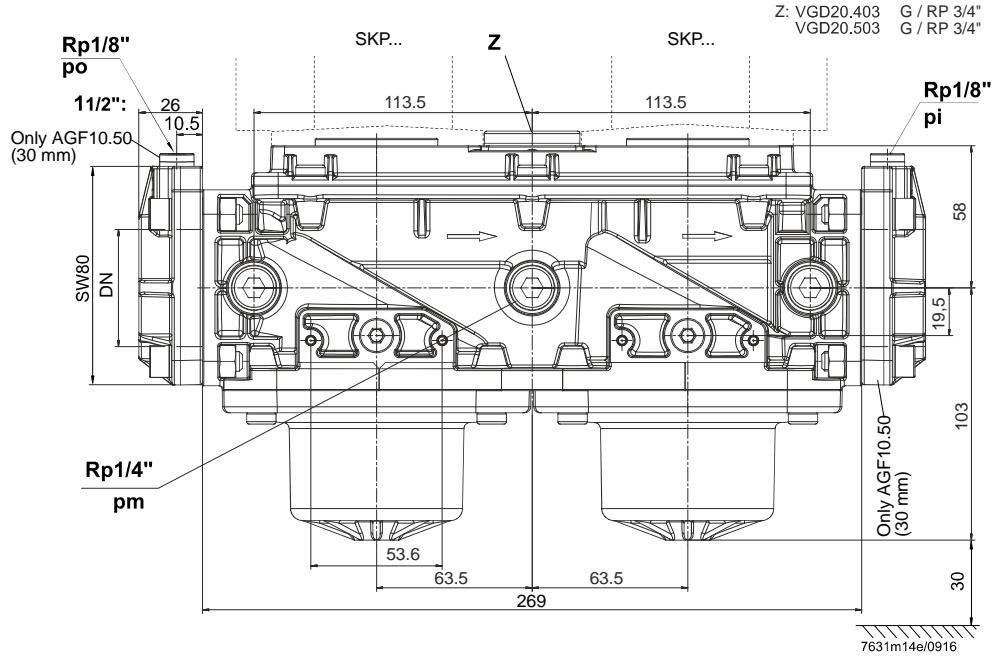

VGD20.xx11... with AGF10... (for dimensions, refer to VGD20.403/VGD20.503)

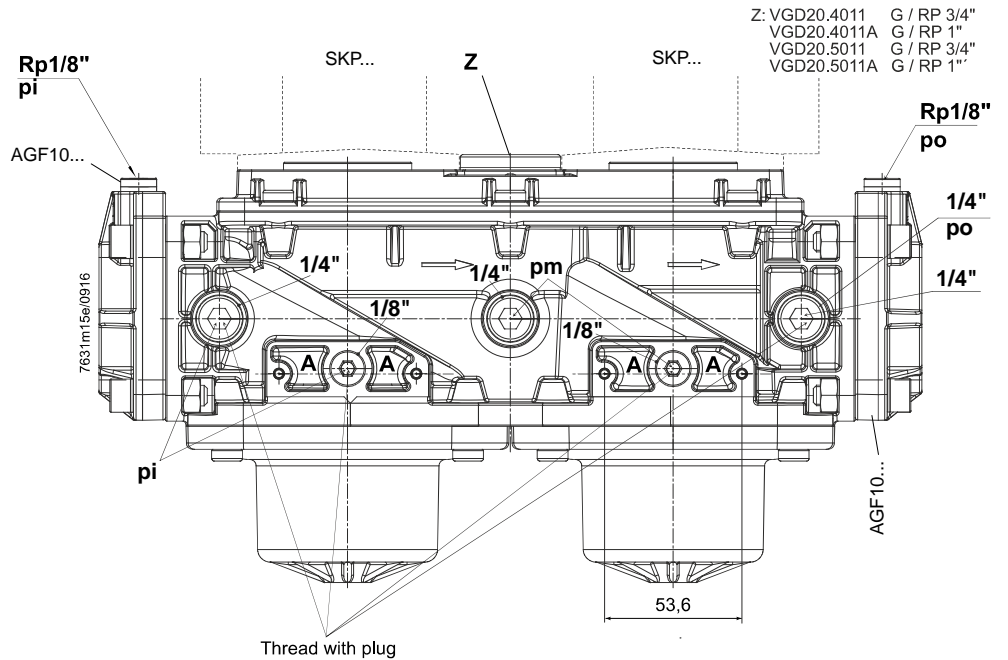

Note!
A = hole for fitting the pressure switch (cheese-head screw M4 self-tapping)!

Dimensions (cont'd)

(Not to scale)

VGD40.../VGD41...

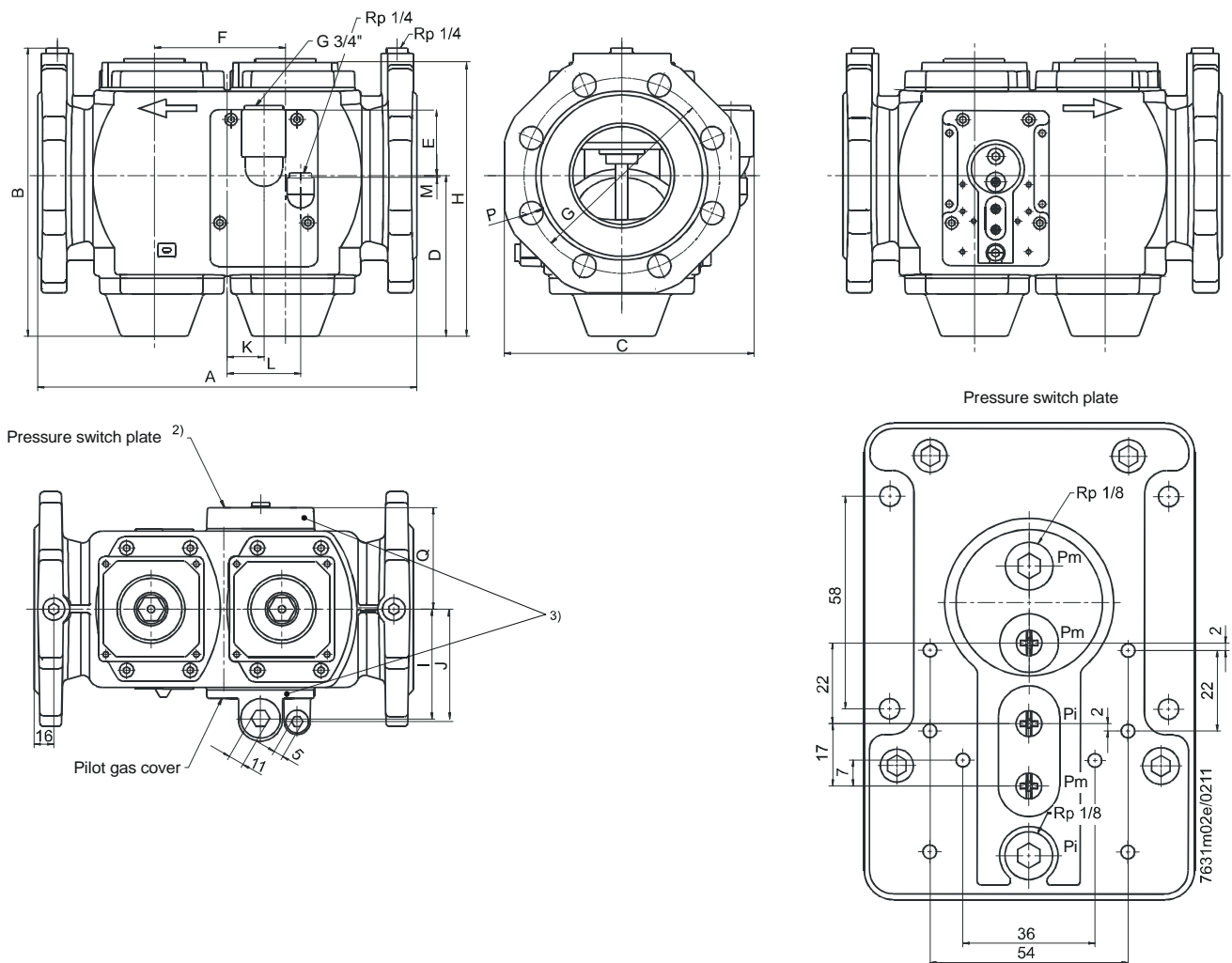

Dimensions

Type	DN ¹⁾	A	B	C	D	E	F	G	H	I	J	K	L	M	P	Q	R	kg
VGD4x.040	40	240	195	168	115	58	88	110	194	77	79	20	50	2	19	70	4	7.0
VGD4x.050	50	240	202	174	115	58	88	125	194	77	79	20	50	2	19	70	4	7.2
VGD4x.065	65	290	215	194	118	60	102	145	200	87	90	30	60	4	19	81	4	8.4
VGD4x.065J	65	290	215	194	118	60	102	140	200	87	90	30	60	4	19	81	4	8.4
VGD4x.080	80	310	236	204	132	54	107	160	224	90	92	30	60	2	19	88	8	9.6
VGD4x.080J	80	310	236	204	132	54	107	150	224	90	92	30	60	2	19	88	8	9.6
VGD4x.100	100	350	259	227	145	43	131	180	255	105	108	41	71	13	19	99	8	12.9
VGD4x.125	125	400	305	255	175	31	150	210	303	119	122	41	71	25	19	113	8	18.2
VGD4x.150	150	480	335	293	188	20	168	240	333	140	143	39	69	36	23	134	8	24.1

- 1) Flanges conforming to ISO 7005-2
 - 2) VGD41... carries a pressure switch plate on both sides and no pilot gas cover
 - 3) With VGD40...L, the mounting position of the 2 plates is reversed
- DN Nominal size, dimensions of connection
R Number of bore-holes in the flange